



# 24<sup>th</sup> Annual Model Bridge Competition 2018 Technical Specifications

Competition Date: Saturday February 3<sup>rd</sup>, 2018

Register for the competition at <http://www.bsces.org/outreach-advocacy/outreach>

Direct link: [CLICK HERE](#)



# WELCOME

The Boston Society of Civil Engineers Section (BSCES) is proud to present the 24<sup>th</sup> annual Model Bridge Contest. This competition serves the important role of introducing students to the world of engineering and design. Through this contest, the BSCES hopes to provide positive role models for the students and allow students to visualize future opportunities in the STEM and engineering fields.

First, thank you for your interest in the BSCES Model Bridge Competition. This document contains all you will need to know regarding model bridge specifications, basic bridge design concepts, and competition schedule and location. The following are the rules and regulations to be followed for the Model Bridge Contest. It is the responsibility of the contestants to follow and construct their bridges in accordance with the rules contained herein.

This year, teams looking for mentors will be matched up with practicing civil engineers to the best of our ability. BSCES would like to remind you that these mentors are volunteers, and will have other commitments throughout the design phase. We expect that each school will be visited by the mentors a minimum of three times prior to the date of the competition, but we cannot promise anything. If you would like greater participation from the mentor program, please contact the bridge coordinator ([bscesmodelbridge@gmail.com](mailto:bscesmodelbridge@gmail.com)). Additional mentors will be provided upon request, subject to availability.

Revisions to the rules in this document are incorporated in clarifications that are published at the bridge competition website, <http://www.bsces.org/outreach-advocacy/outreach>. All clarifications will be emailed to participants. Revisions and clarifications do not appear in the document but are considered addenda to the rules.

# CONTENTS

Welcome.....	1
Bridge Specifications Checklist.....	2
Section 1: Introduction .....	3
Section 2: Competition Participants.....	3
Section 3: Bridge Specifications .....	4
3.1: Materials .....	4
3.2: Bridge Weight Limit .....	5
3.3: Bridge Span.....	5
3.4: Bridge Configuration.....	5
3.5: Loading the Bridge.....	7
3.6: Failure of the Bridge .....	9
Competition Day .....	10

## BRIDGE SPECIFICATIONS CHECKLIST

This checklist is to help you make sure your bridge complies with specifications. Make sure you read through the full specification!

- .. The bridge is completely made of Home Depot brand wooden paint stirrers and hot glue.
- .. The bridge weighs 24 ounces (1.5 pounds) or less. The winner is determined by efficiency ratio (see the Bridge Specifications Section 1). You do not need to build up to the weight limit.
- .. The bridge height is not greater than 24".
- .. The bridge length is between 36" and 40" (for bridges placed on the table surface) -or- bridge length is greater than 40" (for bridges placed on top of the concrete blocks). See the Bridge Specifications Section 3.3 for a figure explaining the bridge lengths and load test setup.
- .. The bridge shall have a roadway that either runs through the bridge or runs over the top side of the bridge. The roadway shall be along the entire length of the bridge so that a scale truck (4" wide by 4" tall by 8" long) could drive from start to end over or through the bridge. The roadway does not need to be a continuous surface, but make sure there are strong supports for the truck to be placed on!
- .. If the roadway goes through the bridge, the scale truck shall fit along the length of the roadway, and the loading apparatus bars shall extend out the sides of the truck (see sketches 3a and 3b in specifications).
- .. The bridge shall be at least 4" wide, but not wider than 7".

## SECTION 1: INTRODUCTION

The goal of this competition is to design and construct a structure with the specified materials that can adhere to the following:

- Clear a span of 36". This can be done with horizontal end restraints at 40" or an unrestrained span of 40". See Section 3.3: Bridge Span for more information.
- Fit a model truck (4" wide x by 4" tall) through the bridge or along the topside of the bridge.
- Hold at least the weight of the scale truck plus loading device (approximately 9 ½ lbs total).

Prizes will be awarded based on the following categories:

- Most Efficient: Bridge efficiency is defined as the ratio of total load supported to self-weight of the bridge. The winner of this award will be the bridge with the highest efficiency value. In the event of a tie, the bridge with the higher aesthetic ranking will be declared the winner.
- Most Aesthetic: Aesthetics is based on craftsmanship, creativity, and display of sound design principles. The winner will be determined by the judges. In the event of a tie, the more efficient bridge will be declared the winner.

## SECTION 2: COMPETITION PARTICIPANTS

This competition is available for students up to 12<sup>th</sup> grade in the Massachusetts area. Competing teams shall be comprised of 2 or 3 students. Teams of only one student or teams of more than 3 students will be disqualified. BSCES is emphasizing the importance of working in a group which is essential to engineering. Participants shall belong to no more than one team and each team shall not register more than one bridge for the competition. If a team would like to load test an additional bridge, they may request an unofficial load test after all registered bridges are tested.

All design and construction work for the model bridge (including devices that assist in fabrication, such as templates) shall be done only by the participants on the team. Teachers, parents, and mentors are encouraged to provide education and guidance, however should not take control of design and construction. The overall goal of the competition is for students to learn how to think like an engineer, and feel the pride that an engineer feels as they successfully build a model bridge of their own design.

It is important that team members present their own bridges and load the bridges themselves. In the event that it is not possible for every team member to attend, at least one team member is required to participate in the loading of their bridge. Models brought to the competition without any team members may be tested after the contest but will not be eligible for prizes.

## SECTION 3: BRIDGE SPECIFICATIONS

All of the following rules and specifications within this section must be followed in order to qualify for this contest. BSCES will disqualify any bridge that does not conform to these specifications.

### 3.1 Materials

1. Bridges shall be built entirely of the following materials
  - a. Home Depot standard wooden paint stirrers. These can be picked up at any home depot painting center free of charge. They are approximately 1'-0" long x 1" wide x 1/8" thick. Do not use any other size or any other brand of paint stirrer.
  - b. Surebonder DT-25 All Purpose Stik Mini Glue Sticks, Clear hot glue. This brand can be bought at Amazon, Jo-Ann Fabric, Michael's Store, Walmart, or Staples.

Use of any other material or brand of material will be grounds for disqualification. Teams will be provided with an initial package of materials, but additional materials shall be purchased by the team.

2. Unapplied glue sticks shall not be used as a component of the bridge. Glue sticks shall only be used as glue to supply the glue gun.
3. Structures may not be brushed, sprayed, or dipped in any coating material. This includes, but is not limited to, coatings such as paint, stickers, glue, fabric, or any filmlike material. Non-structural decoration (markers, pens, pencils, crayons, etc.) of the bridges is encouraged. All questionable materials should be checked with the model bridge coordinator ([bscesmodelbridge@gmail.com](mailto:bscesmodelbridge@gmail.com)) before being used. BSCES requests that any decorations be tasteful and appropriate. Inappropriate markings on the bridges will be grounds for disqualification at the judging panel's discretion.
4. Once the bridges are loaded, another inspection of the bridges by the judging panel will be made to ensure that the proper materials were used.

ALL DECISIONS OF THE JUDGES ARE FINAL

### 3.2: Bridge Weight Limit

The total weight of the structure (weight of members and the weight of adhesives) shall be no more than 24 ounces (1.5 pound). Bridges that exceed this weight limit will be disqualified.

### 3.3: Bridge Span

The bridge will span between tables that are 36 inches apart. There will be 8" tall concrete blocks that will be secured to each table 2" from the edge. The bridge may rest on the top surface of the table between the concrete blocks OR may sit on top of the concrete blocks. The bridge cannot be attached to the blocks in any way. The bottom of the bridge ends (the bearing area) must be level and stable and the bridge must be able to stand on its own under the effects of gravity.

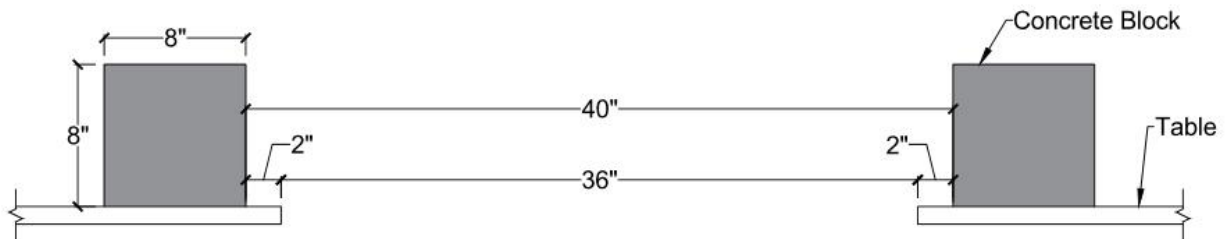

Figure 1: Span of Bridge

Bridges Placed on the Table Surface: If the bridge rests on the table surface, it will need to span across the 36" gap, but shall be less than 40".

Bridges Placed on Top of Concrete Blocks: If the bridge rests on top of the concrete blocks instead of the table, it will need to span across the 40" between blocks. This means that the bridge deck will need to be longer than 40" and have enough length to rest on each block, at least 42" length is recommended for this.

### 3.4: Bridge Configuration

1. No portion of the bridge shall extend more than 24" above the table surface (16" above the top surface of the concrete blocks)
2. No portion of the bridge shall extend below the top surface of the table. Bridges will be permitted to extend below the top surface of the table only if it is due to incidental deflection of the bridge under loading (but note the amount of deflection permitted due to load is limited). See *Failure of Bridge* Section 3.6 for more information

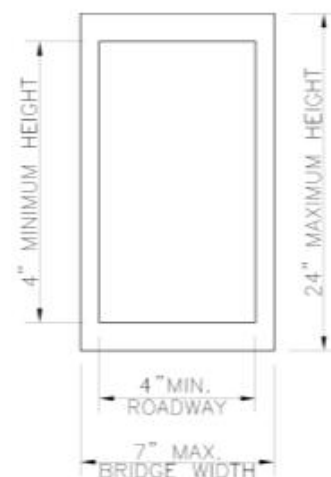

Figure 2: Cross Section of Bridge with Roadway through Bridge

3. The overall width is limited to 7 inches maximum. The roadway width shall be a minimum of 4 inches. The roadway is defined as the distance between the sides of the bridge (in the case of a through truss) or the overall width of the bridge when the roadway is on top of the bridge. See Figure 2 and Figure 3.

- The roadway/loading surface must be provided at all potential wheel support locations (refer to Figure 7). Since the truck that is loaded has “wheels” that are each 2” wide, the roadway shall have enough material to prevent the wheel from falling through. There should not be any obstructions that would prohibit the truck from “driving” across the bridge span.
- The 4” minimum shown in Figure 2 only applies if the roadway is inside the bridge. There is no minimum height if the roadway is on the top of the bridge. See Figure 3.

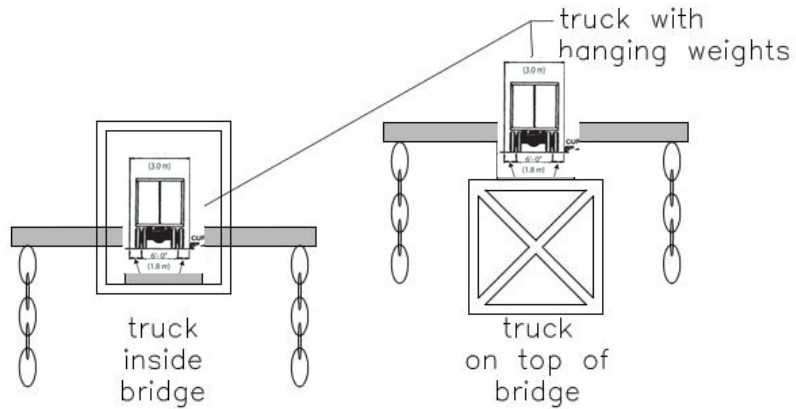

Figure 3a: Different Ways to Load the Bridge Section Views

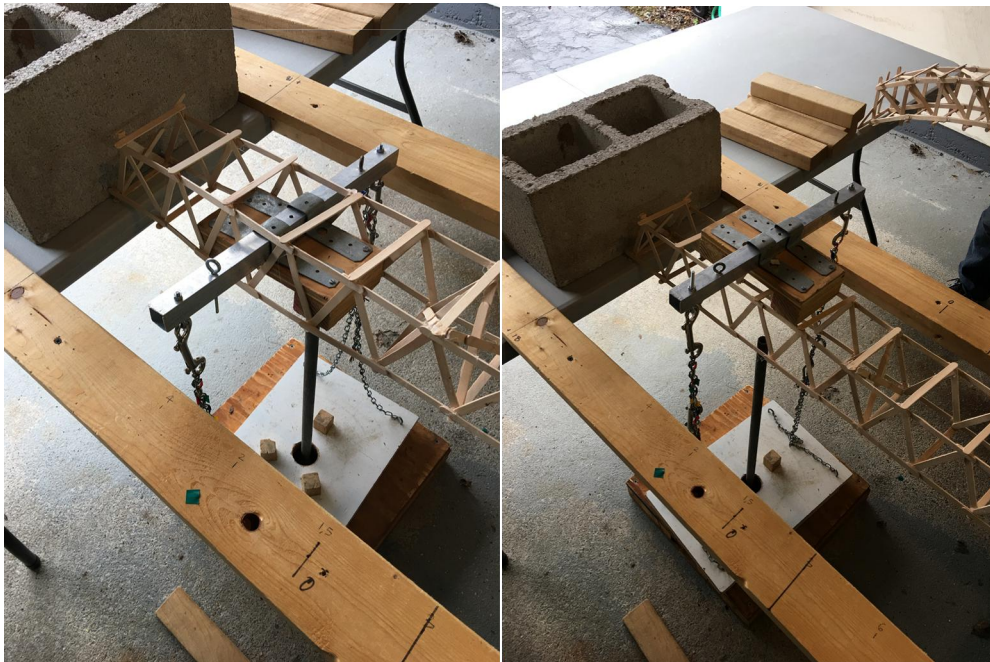

Figure 3b: Different Ways to Load the Bridge – Photos

### 3.5: Loading the Bridge

The model truck that will be placed on the bridge has the following dimensions and properties:

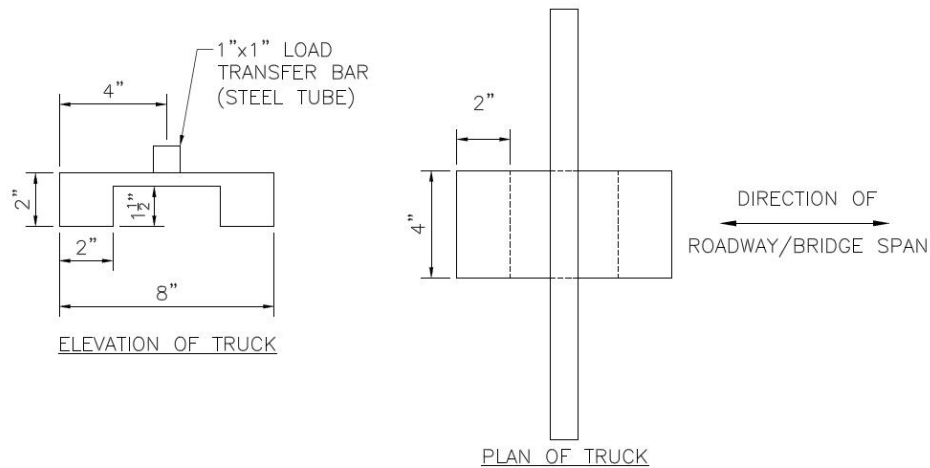

Figure 4: Details of Truck

1. In order to be loaded, the bridge shall (at a minimum) be capable of supporting an initial weight of the loading apparatus (approximately 2 lb truck + 7.5 lb loading platform = 9.5 lbs).
2. The truck will be placed on the loading surface at a point that will be determined by the roll of a die at the beginning of the competition (see Figure 7). The random point will remain the same for all teams. A load transfer bar will be placed across the top of the truck with chains connected at each end extending downward to connect to a loading platform beneath the structure. Each student will then load their own structure by placing the supplied weights onto the loading platform until failure.
3. Loading is limited to 250 lbs. of free weights. Loading is also limited to the top of the center support pole (18.5"). Lighter weights, when stacked, will take up more height than heavier weights, when stacked so keep this in mind when selecting which weights to load. Once loads are applied (touch the weight below), they cannot be removed. Any load being applied at the time of bridge failure will not be counted towards the recorded loading. At the moment a newly applied weight touches the weights below it all weights below are official. It is completely the responsibility of the design team to decide how best to apply the loads.
4. The loading apparatus (truck + loading platform) must be capable of being supported on the loading surface (roadway) as shown in the diagram. This means that your structure **MUST** have enough roadway surface for the truck to be placed at one of the six locations along span (see Figure 7), but does not need a continuous surface. The roadway should be reasonably level (some arch is permitted) from one end of the bridge to the other without obstruction. Bridges with roadways that have excessive slope causing the truck to slide off of the bridge will be disqualified.



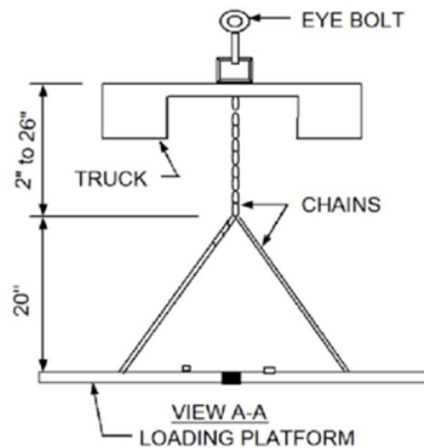

Figure 5: Loading Apparatus with Truck

5. If the roadway surface is not along the top of structure, the design must allow for a 1" x 1" load transfer bar (see Figure 4) to be passed through the bridge transversely with the bar's underside 2" above the loading surface, without causing interference with the structure during testing. The design must accommodate the truck being placed in any of the possible loading areas.

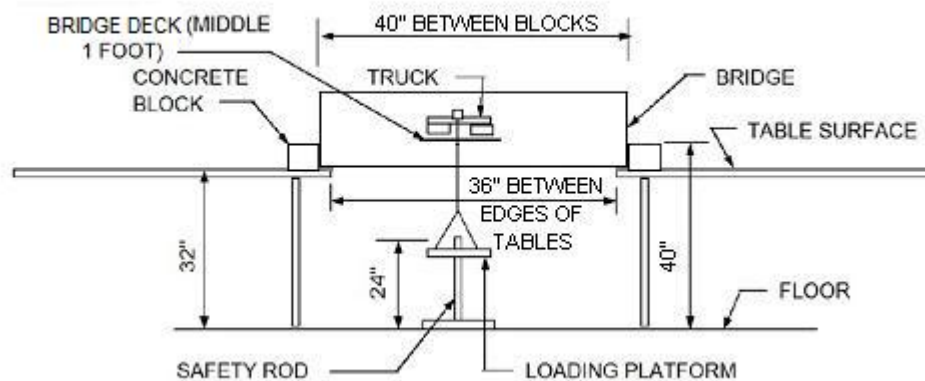

Figure 6: Sketch of Bridge with Roadway Surface through Bridge

6. The concrete blocks provided on the loading tables are there for bridges that exert a horizontal force (e.g. arch bridges). These concrete blocks will be restrained and unable to slide apart. In cases where the bridge exerts a horizontal force on the blocks (e.g. thrust from arch bridges), the blocks can be counted on to resist horizontal forces. If your design intent is to utilize the concrete blocks to resist horizontal thrust, please limit the end to end length of your structure to be under 40" by at least 1/16". We will fill the small gap with index card shims. It is the responsibility of the designers to have gaps of consistent width. Each shim will be placed alongside and parallel to each other.

7. Make sure your bridge fits between the concrete blocks or on top of them. The blocks will be placed in the loading frame on the tables and will not be removed at any time during the competition. The loading apparatus will be available to test bridge fit during registration.
8. In order for a bridge to be selected as the most aesthetically pleasing bridge, it must carry the minimum specified weight (9.5 lbs = loading device + truck).
9. Teams MUST wear safety glasses or goggles at all times while testing their bridges. If a team member is not wearing safety glasses or goggles, testing of a team's bridge will immediately stop until all members put them on. If a team has to be warned a second time, they will be disqualified.
10. In the event that the team members have physical challenges preventing them or presenting a safety risk in their placing of the weights, a non-team member may do so, but the team member must direct each move of the person loading the bridge.

The random loading points shall be as shown in the figure below:

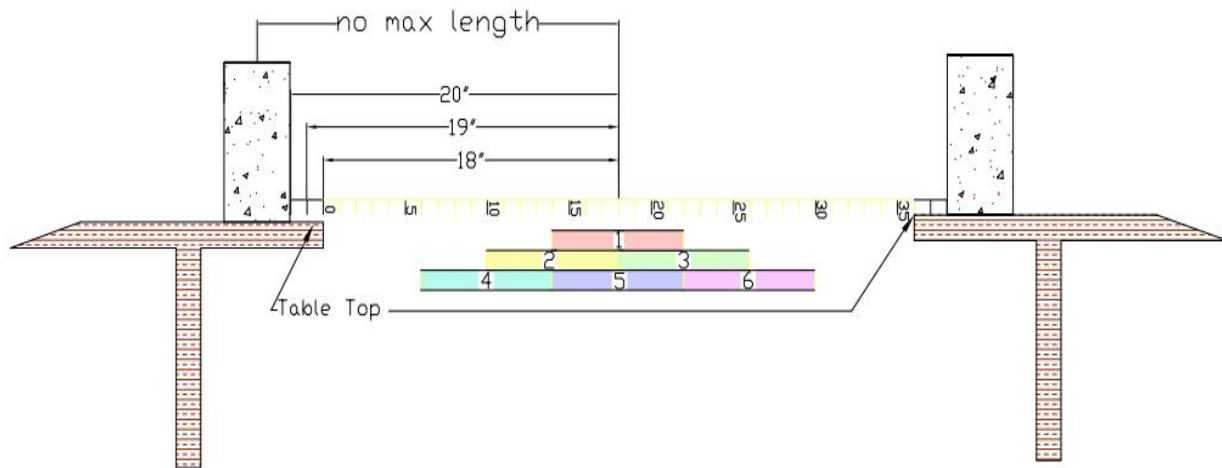

Figure 7: Possible Loading Positions

The various colored blocks represent the 8" long truck, each color representing a possible loading position. Position 1 and 5 are centered on the bridge. All other positions are 4" intervals of position 1.

### 3.6: Failure of the Bridge

1. Failure is defined as a fracture of the members or deflection of the structure causing the truck to settle more than 2" (dropping the weights to the base). Slippage from the bearings or overturning of the structure is also considered failure.
2. Settlement is measured as the difference between the initial height (with the 9.5 lb load) and a final height of the loading truck (with the 9.5 lb initial load plus additional weights) to the surface below.

The bridge fails when it is incapable of supporting any additional load without exceeding the deflection or fracture limit.

## COMPETITION DAY

At Wentworth Institute of Technology, 550 Huntington Ave, Boston, MA 02115.

Registration: Teams are to report to the Registration table between 8:30 and 9:30 a.m.

Weigh In: A panel of technical judges will review the bridges for compliance (weight, width, length, roadway and loading surface) with the contest rules. Teams with bridges that are found to be in violation of the rules will be given a grace period to modify and re-submit their bridges. **ONLY STUDENT TEAM MEMBERS ARE ALLOWED TO MAKE ANY MODIFICATIONS (NO TEACHERS OR MENTORS)**. Once a model is accepted and placed in the judging area, it is not allowed to leave that area until it is loaded, and no alterations are allowed at any time after the bridge is accepted, unless the judges deem it acceptable to make a modification as a result of a challenge (see below).

The grace period for modifications will end at 10:00 a.m. Not meeting this deadline is grounds for disqualification.

Challenges: After the bridges are weighed in, contestants may VISUALLY inspect other contestants' bridges for compliance with the rules. Any bridge suspected of being in violation of the contest rules may be brought to the attention of the judges. Only students with bridges passing the Technical Judging may present challenges.

The judges will rule on any challenge presented to them. Both the challenger's bridge and the bridge being challenged will be reexamined for conformance with these specifications.

Where possible, challenges presented will allow modification of the bridges that are in violation of the rules to make them compliant and to avoid disqualification.

The judges' decisions will be final. Any challenges, complaints, or appeals after the modification time period will not be allowed.

Disqualified bridges may be load-tested but will not qualify for any awards.

Aesthetic: The bridges will be examined for aesthetically pleasing design before any bridges are load tested. Please note that in order for a bridge to be selected as the most aesthetically pleasing bridge, it must carry the minimum load of *9.5 lbs (the weight of the loading apparatus)*.

Load Testing: Each contestant will apply loads to their bridge on the loading platform previously described until failure. Failure is defined as fracture, inability to support loads, or deflection of the structure causing more than 2" of deflection (measured from the original elevation of the "truck" assembly). The maximum load supported by the bridge (ultimate load) prior to failure will be recorded. Teams that do not want their bridge tested to failure may stop the loading any time after the minimum weight has been applied. Safety goggles (that will be provided by BSCES) will be worn by students while loading their bridges for safety purposes. Any team members involved in testing not wearing will result in disqualification.